



1

## Netter Electric Internal Vibrators Series NCZ and NCZ/S



- Higher centrifugal forces than conventional vibrators
- Special suspension of the eccentric weight
- Head tungsten carbide coating
- Maximum lifetime due to thermosensores
- Interchangeable elements
- Nominal frequency 12.000 min<sup>-1</sup>
- Centrifugal force from 1.160 N to 10.470 N
- Compacting efficiency 16 m<sup>3</sup>/h to 65 m<sup>3</sup>/h
- 42 V to 48 V, 200 Hz or 250 V, 200 Hz



NCZ



NCZ/S



# NetterVibration



## Netter Electric Internal Vibrators Series NCZ and NCZ/S

Type	Head diameter	Head length	Head weight	Total weight	Hose length*	Cable length*	Nominal frequency	Centrifugal force	Influenced zone	Current consumption mean	Voltage*	Power (42 V)
	[mm]	[mm]	[kg]	[kg]	[m]	[m]	[min <sup>-1</sup> ]	[N]	[cm]	[A]	[V]	[kW]
NCZ 300	32	320	1,7	7,9	5	10	12.000	1.160	40	8	42-48	0,6
NCZ 300 S	32	320	1,7	6,6	0,83	15	12.000	1.160	40	8	42-48	0,6
NCZ 370	38	360	2,9	9,6	5	10	12.000	1.400	45	8	42-48	0,6
NCZ 370 S	38	360	2,9	5,0	0,83	15	12.000	1.400	45	8	42-48	0,6
NCZ 480	49	400	5,1	14,2	5	10	12.000	3.100	60	15	42-48	1,1
NCZ 480 S	49	400	5,1	6,2	0,83	15	12.000	3.100	60	15	42-48	1,1
NCZ 560	58,5	400	6,8	15,9	5	10	12.000	4.850	65	23	42-48	1,6
NCZ 560 S	58,5	400	6,8	6,8	0,83	15	12.000	4.850	65	23	42-48	1,6
NCZ 560 L	58,5	450	7,8	16,8	5	10	12.000	6.100	75	21	42-48	1,5
NCZ 560 LS	58,5	450	7,8	9,2	0,83	15	12.000	6.100	70	21	42-48	1,5
NCZ 660	66	510	11,4	21,4	5	10	12.000	8.500	110	27	42-48	1,9
NCZ 800	80	440	13,8	29,0	5	10	12.000	10.470	160	35	42-48	2,5

\*Other voltages, cable lengths and hose lengths on request

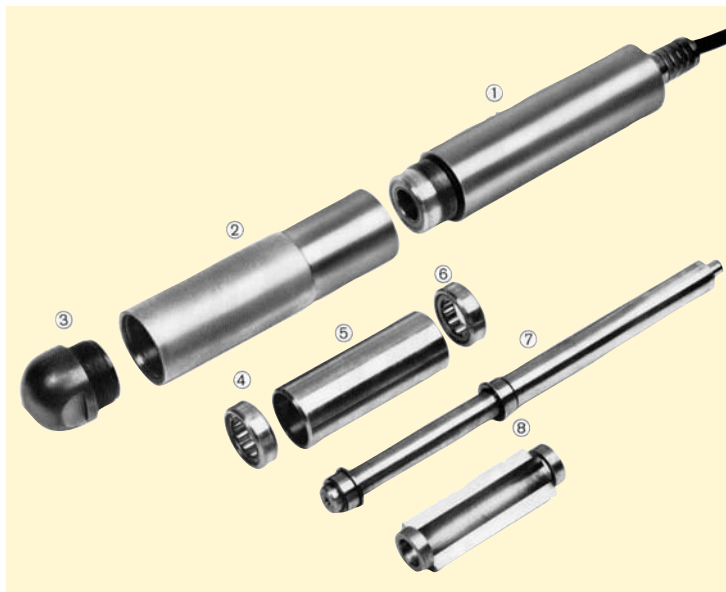

### The Netter modular design:

8 interchangeable elements can be assembled without special tools on the construction site:

- 1 – stator with thermosensors (one per phase)
- 2 – body
- 3 – steel or rubber nose pieces
- 4 – ball or roller bearing
- 5 – spacer
- 6 – ball or roller bearing
- 7 – rotor
- 8 – eccentric weight made of bronze

### Applications

The high power series NCZ and NCZ/S electric internal vibrators are particularly suitable for achieving high compaction performance with optimum extraction of air porosity, due to their enormous centrifugal forces.

NCZ vibrators thus fulfil the requirements of modern concrete technology.

The modular construction makes these internal vibrators very easy to service.

The special unbalance suspension and the long operating life of the bearings guarantee long-term reliability.

The coil is 100% protected from burning out by means of thermal sensors. In the event of overheating, the unit switches off automatically.

Series NCZ/S electric internal vibrators have a hand switch shaped like a pistol grip. The shorter connection hose is adapted to suit the special applications of concrete plants.

NCZ electric vibrators can be operated using all converters from 42 V to 48 V, 200 Hz .

**NetterVibration** supplies frequency and voltage converters suitable for all electric vibrators.

### Permissible operating conditions

#### Voltage:

42 to 48 V, 200 Hz or 250 V, 200 Hz

#### Ambient temperature:

0°C to 40°C

### Netter GmbH

#### Germany

Fritz-Ullmann-Str. 9  
55252 Mainz-Kastel  
Tel. +49 6134 2901-0  
Fax +49 6134 2901-33

#### Switzerland

Erlenweg 4  
4310 Rheinfelden  
Tel. +41 61 8316200  
Fax +41 61 8311291

#### Poland

Al. W. Korfańtego 195/17  
40-153 Katowice  
Tel. +48 32 2050947  
Fax +48 32 2051572

www.**NetterVibration**.com  
info@**NetterVibration**.com

**Netter provides solutions. Consult our experienced application technicians.**